

- **Plates and beams**

Extensive checks for crack and deflection control in serviceability limit case (SLS) for plates and beams, effects of creep and shrinkage. Eurocode 2 §7.

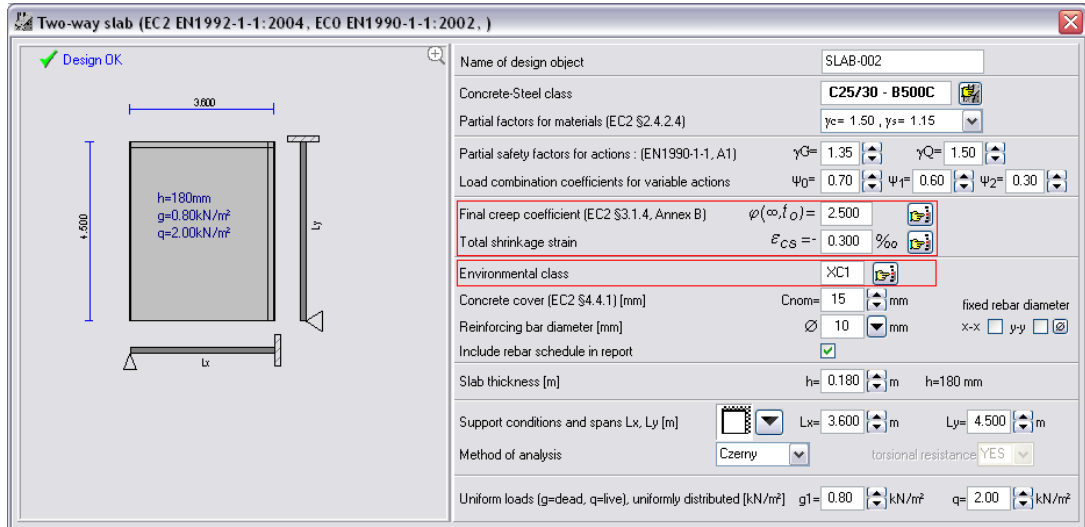

- **Isolated columns analysis** (single and double bending with axial force) for second order effects according to 2 §5.8, 5.87.3 Moment magnification factor.

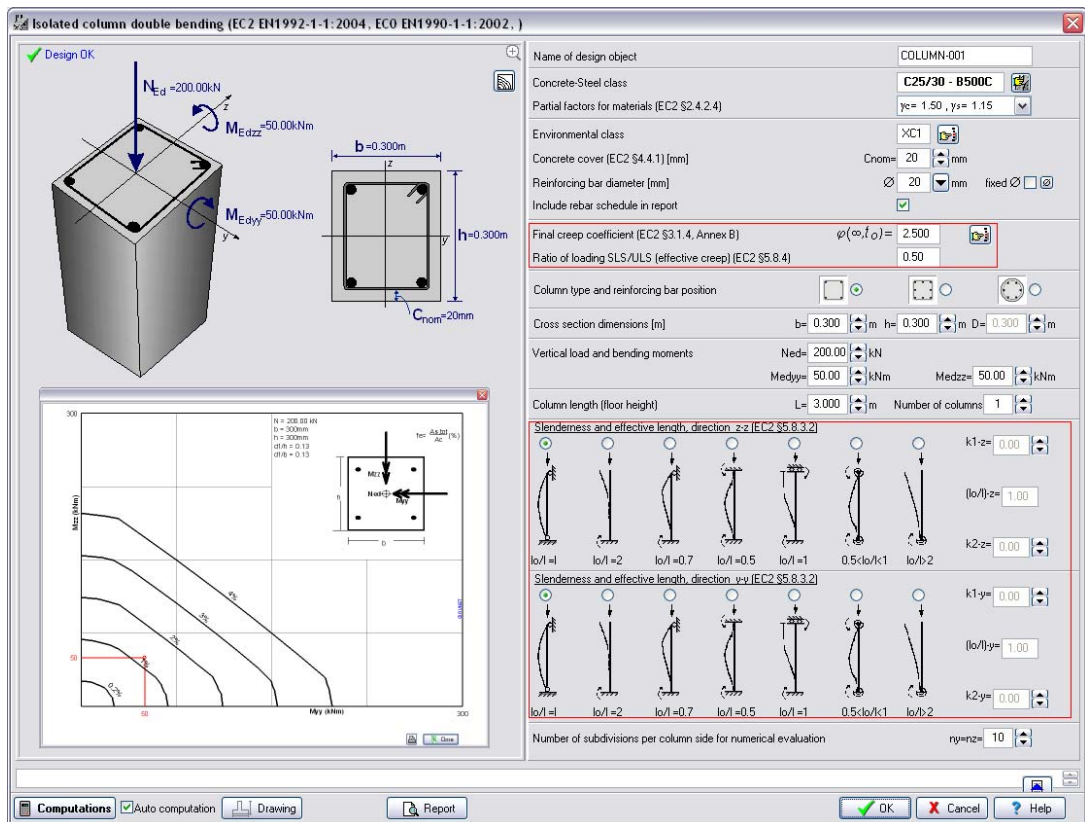

- New Menu with Dimensioning of plates and beams form **Light Concrete** according to Eurocode 2 §11.

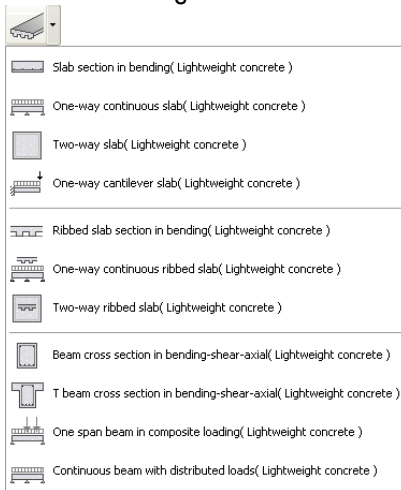

- Charts and graphs for use and understanding of Eurocode 2.

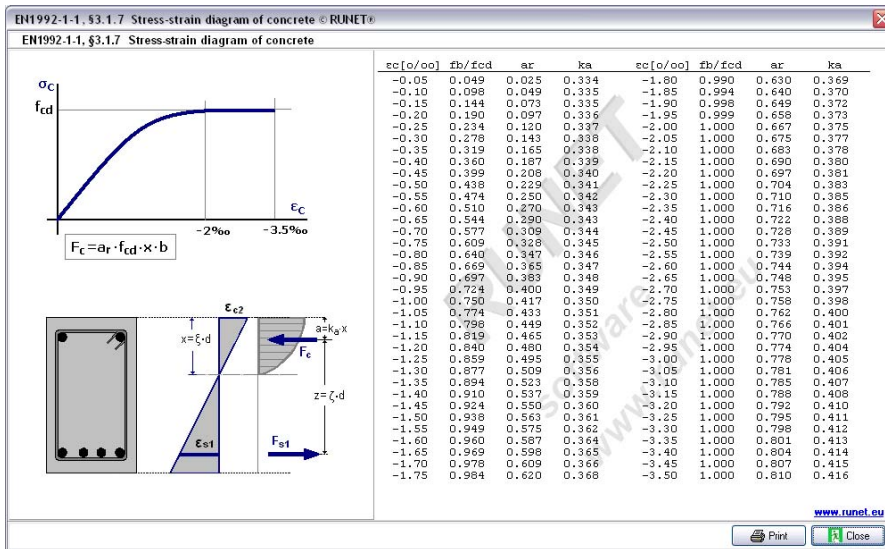

- Design Charts and Tables for dimensioning with Eurocode 2, Tables Kd, med  $\omega$ .

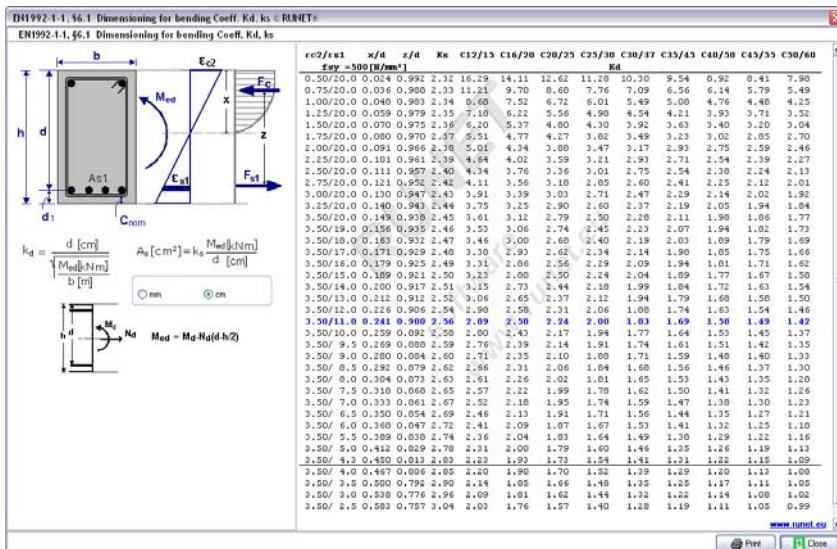

- Design charts for columns in single and double bending.

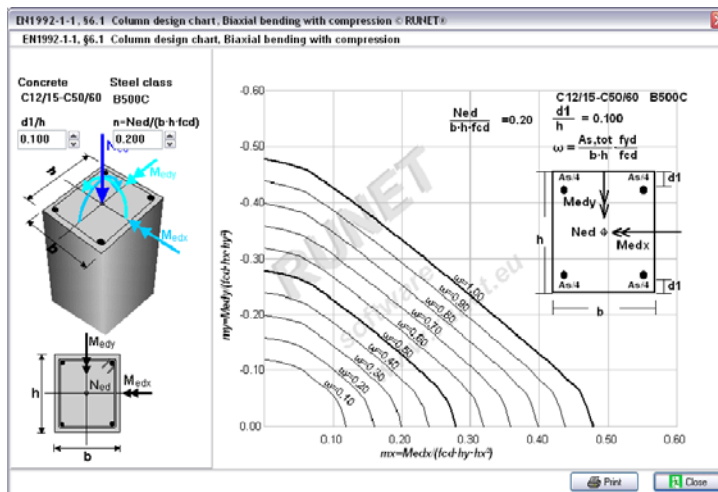
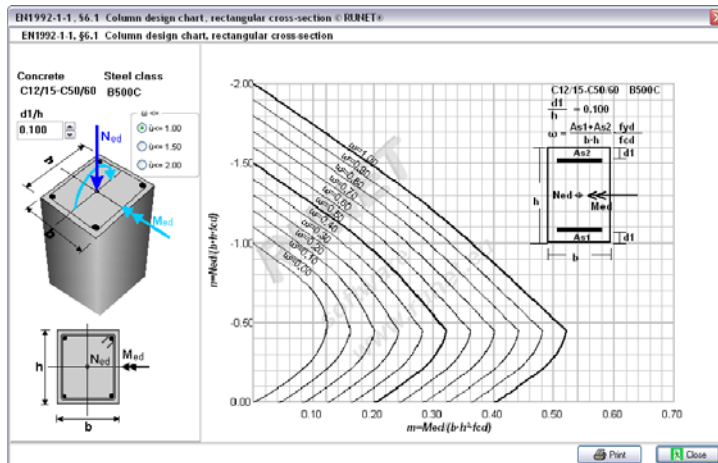

- Design charts for deflection control

